

Pharmmenta™



AptiPort™

Sampling Valve

- ☑ Positive drainage even from inclined portholes.
- ☑ Cleans and sterilizes in place (CIP/SIP).
- ☑ Install in existing portholes in seconds.
- ☑ Sanitary, crevice-free design.
- ☑ Suitable for research or production.
- ☑ Fits 3/4 inch (19mm) or 1 inch (25 mm) portholes.
- ☑ 316L Stainless Steel construction.
- ☑ Your choice of actuators, diaphragm materials and connections.
- ☑ Application industries: pharmaceutical, biotech, food, beverage, fine chemical.

Pharmenta™ AptiPort™ Sampling Valve™

The Pharmenta™ AptiPort™ sampling valve is the first and only sampling device that installs and fully drains from practically any porthole, including inclined sensor portholes.

The Problem

Typically, when you want to install a sampling valve, you must choose a location on your tank from which to sample, and have a special sampling port welded into your tank. Then forever, you will have to sample from that location, regardless of process changes. If you want to sample from more than one location on the tank, it may not be possible. There may be plenty of sensor portholes on your tank, but they are all angled upward, and cannot be used for drawing samples. That is, until now.

The Solution

Now you can sample from practically any porthole in your tank, including sensor portholes. The Pharmenta AptiPort™ sampling valve offers a unique combination of patented technologies focused on delivering clean, representative samples in a range of situations.

Positive Drainage from Inclined Portholes

The AptiPort™ sampling valve's patented design offers a space-saving combination of orifice and drain passage arrangements that permits positive drainage of sample material. Fluid drains down and out of the valve, even when it is installed in an upward oriented porthole.

Vortex-Flo™ Scrubbing Action

Engineered flow paths through the AptiPort™ sampling valve generate a spinning flow at the high flow rates used during CIP and SIP operations. This Vortex-Flo™ action scours internal surfaces to remove stubborn particulates and surface residues, leaving passages pristine and contaminant-free so that there are no surprises during your next sampling operation.

Optional HeatShield™ Valve Jacket Insulation

For processes that require steam reesterilization, the Pharmenta AptiPort™ valve offers optional valve jacket insulation. This insulation inhibits heat transfer into the process during steam reesterilization, which might otherwise adversely

affect the process.

Facilitates Sampling Standardization

The AptiPort™ sampling valve enables you to transfer your sampling methods easily from one tank to another in scale up and post-approval change situations. It has exactly the same internal passage geometry in both 3/4" and 1" sizes, so samples taken through the smaller porthole sizes found on research tanks will be physically the same as those taken from larger porthole sizes found on production tanks, eliminating another variable and making scale-up easier for you.

Flexible, Trouble-free Design

The AptiPort™ sampling valve features a simple, versatile design that provides for improved reliability and fast, easy maintenance. It can be moved from port to port in seconds because it installs like a sensor probe (with your choice of a variety of connection types.)

The AptiPort™ sampling valve is effective in portholes angled up in excess of 15° to those angled down in excess of 15°, and everything in between. Its sanitary, crevice-free design is cleanable and steam sterilizable-in-place and suitable for both research and production applications for a range of industries.

The AptiPort™ sampling valve is available with diaphragms in a variety of biocompatible materials. It comes in valve body sizes to fit 3/4" and 1" portholes. Your choice of pneumatic, manual handwheel or lever actuators are available.

With the Pharmenta AptiPort™ sampling valve, a new standard of sampling is born, offering both the flexibility and high-quality performance you need to standardize all of your sampling methods.



Cross-section of the Pharmenta™ AptiPort™ sampling valve installed in an inclined sensor porthole.

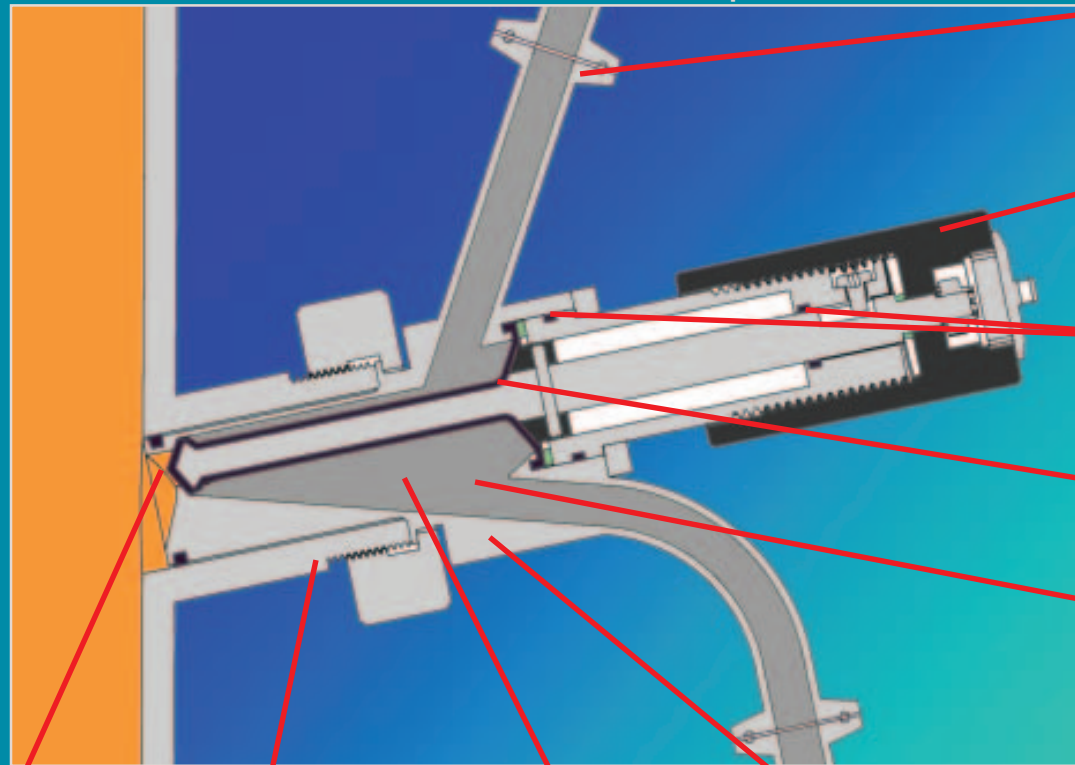

Choice of sanitary clamp or butt-weld inlet and outlet connections. Custom connections also available.

Choice of pneumatic or manual lever or handwheel actuator.

O-ring backup seals to contain any primary seal leakage.

Rear-installing sanitary radial diaphragm for fast, easy maintenance.

Fluids drain down and out of valve even when installed in inclined portholes.

Optional HeatShield™ valve insulation (not shown) protects process during steam re-sterilization and inhibits heat induced plaque buildup.

Large bore sample orifice opens directly into process.

Installs in any standard 3/4" (19mm) or 1" (25 mm) porthole, including sensor portholes.

Smooth, declining internal passages to enhance drainability, cleanability and sterilizability.

Valve body machined from 316L stainless steel.

The Pharmenta™ AptiPort™ sampling valve in operation.

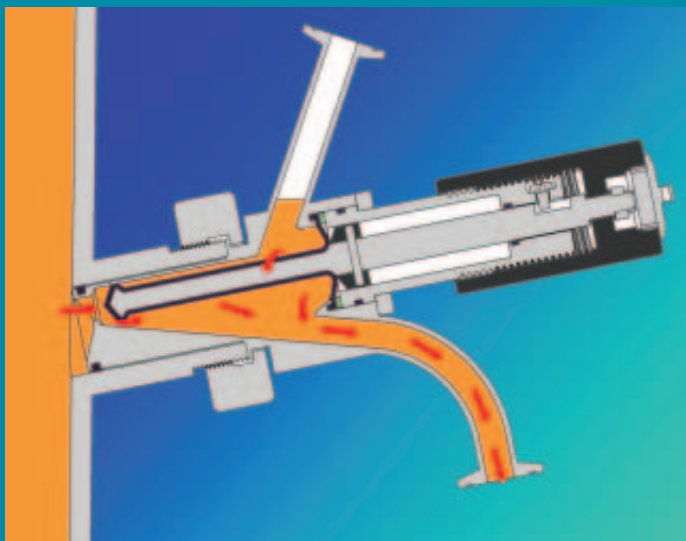

Valve open for sampling. Since all internal surfaces are smooth and declining, process material quickly flows down and out, even when installed in an inclined porthole.

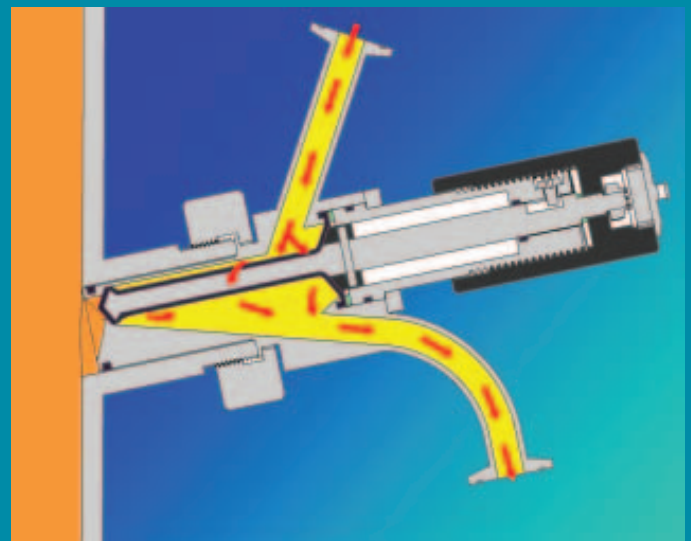

Valve closed for cleaning and sterilizing. Solutions, rinses and condensate automatically drain down and out, even when installed in an inclined porthole.

Pharmenta AptiPort™ Sampling Valve™

Technical Specifications

Body Material: 316L stainless steel
Maximum Temperature: Diaphragm: 260° F (125°C)
Maximum Pressure: Diaphragm: 50psi (4.0 bar)
Autoclavable: Yes

How to Specify

To specify your Pharmenta AptiPort™ sampling valve choose desired options from each category:

Valve Size:

- 3/4 inch (19mm) O.D. 1 inch (25mm) O. D.

FDA Compliant Diaphragm Material:

- EPDM PTFE Teflon® Buna N Viton® Silicon

Actuator Style:

- Manual handwheel Manual lever Pneumatic

Valve Mounting Configuration:

- Standard threaded collar
 Custom threaded collar: _____
 Sanitary clamp: Specify flange size: _____

Body Style:

- Standard Insulated

Inlet End Connection:

- 1/2" Sanitary clamp (3/8" O.D. tube) 3/8" O.D. butt weld tube
 Custom: _____

Outlet End Connection:

- 1/2" Sanitary clamp (3/8" O.D. tube) 3/8" O.D. butt weld tube
 Custom: _____

Surface Finishes:

Interior:

- Standard 20-25Ra (180 grit) 15-20Ra (240 grit)
 Electropolish Custom: _____

Exterior:

- Standard 20-25Ra (180 grit) 15-20Ra (240 grit)
 Electropolish Custom: _____

Product presentations herein, including dimensions, designs, photographs and diagrams, are representative of product availability at time of publication only. Product is subject to design and manufacturing changes without notice.

Pharmenta, the Pharmenta logo, AptiPort, SIPTube, Deep-Loop, Vortex-Flo and HeatShield are trademarks or registered trademarks of N. L. Technologies, Ltd. All other trademarks are the property of their respective owners. The Pharmenta AptiPort sampling valve is protected by U.S. patents: 5,296,197; 5,525,301; 5,786,209; 6,133,022, 6,345,640 and other U.S. and foreign patents and patents pending.

© 2002 N.L. Technologies, Ltd. All rights reserved. Printed in the USA.

AP1704 04/02

Pharmenta's mission is to improve the safety, quality, efficiency and consistency of industrial products and processes through innovative equipment design.

Pharmenta is a product division of N. L. Technologies, Ltd. Since 1989, N. L. Technologies has provided regulatory and facility design expertise to pharmaceutical, biotech, chemical, food and beverage manufacturers around the world.

Pharmenta, Inc.

P.O. Box 7788
Princeton, NJ 08543-7788
U.S.A.

Phone (888) 765-7838 (Toll Free)
(609) 919-6370

Fax (609) 452-7127

Email answers@pharmenta.com

Web www.pharmenta.com

Pharmenta
Innovative solutions for innovative industries
From NL Technologies, Ltd.